

Regional strategies around convergence of  
HPC, AI and Quantum Computing – General roadmaps and projects

## JHPC-Quantum project

# For QC-HPC hybrid computing with **on-premises** Quantum Computers

**Mitsuhisa Sato**, Division Director, Quantum HPC Hybrid Computing Platform Division  
RIKEN Center for Computational Science (R-CCS)

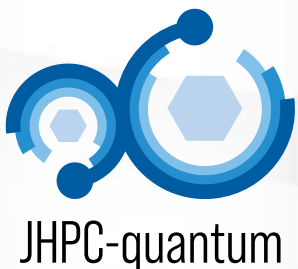

# Quantum Computing Researches in RIKEN

- **RIKEN Center for Quantum Computing (RQC)**
  - R&D of various qubits---superconducting, optical, semiconductor, neutral atoms... domestic machine
  - Quantum computing theory
- **RIKEN Center for Computational Science (R-CCS)**
  - R&D for hybrid computing system with Fugaku and quantum computers for 'real' workloads
  - Development of quantum computers simulators on Fugaku
  - Feasibility study on technologies for integration of quantum computers in the next flagship supercomputer project
- **iTHEMS (Interdisciplinary Theoretical and Mathematical Sciences Program), RIKEN Quantum**
  - Theory and algorithms of quantum computing

観 (A) :  
64 qubit  
superconducting  
quantum computer

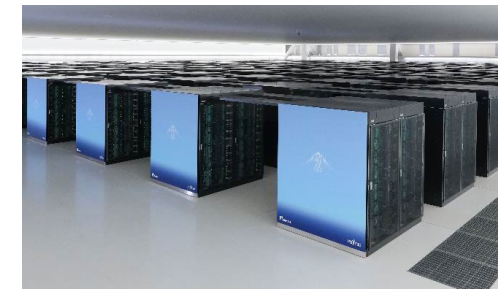
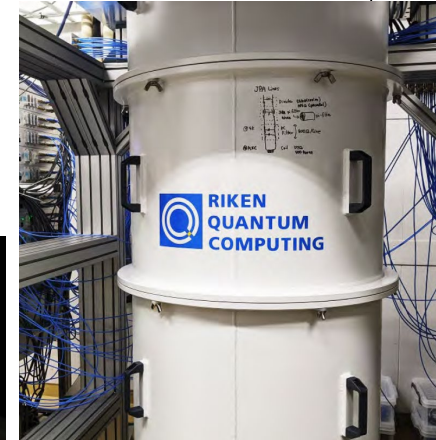
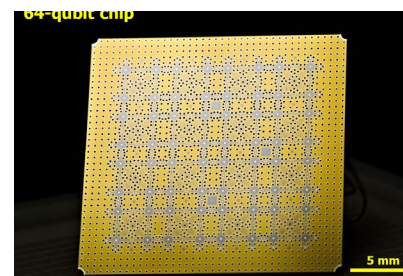

## Comprehensive initiatives across three pillars

- Domestic Actual Machine Development: RQC x Fujitsu Collaboration Center 21 teams, 90 members (full-time)
- Computational Science ('Useful' QC-HPC): Approx. 20 members in R-CCS QC-HPC Division
- Quantum Information Science: Approx. 120 individuals utilizing QII quantum computers at RIKEN Quantum



- Project Period: Nov 2023 – Oct 2028 (5years)
- Members: RIKEN, Softbank, U. Tokyo and Osaka Univ.

## • Missions

- Research and development of **quantum HPC hybrid system software** for the integration of quantum computers and supercomputers (HPC) are conducted.
- Using the system software, a **quantum-supercomputer hybrid platform** is built with two types of quantum computers, IBM superconductive QPU and Quantinuum trapped-ion QPU, and supercomputers including Fugaku.
- As well as demonstrating the advantage (and **“Utility”**) of **quantum HPC hybrid applications** against existing applications only by supercomputers, advanced internet technology will be developed to deploy the quantum HPC hybrid applications as **a service in the post-5G era**.

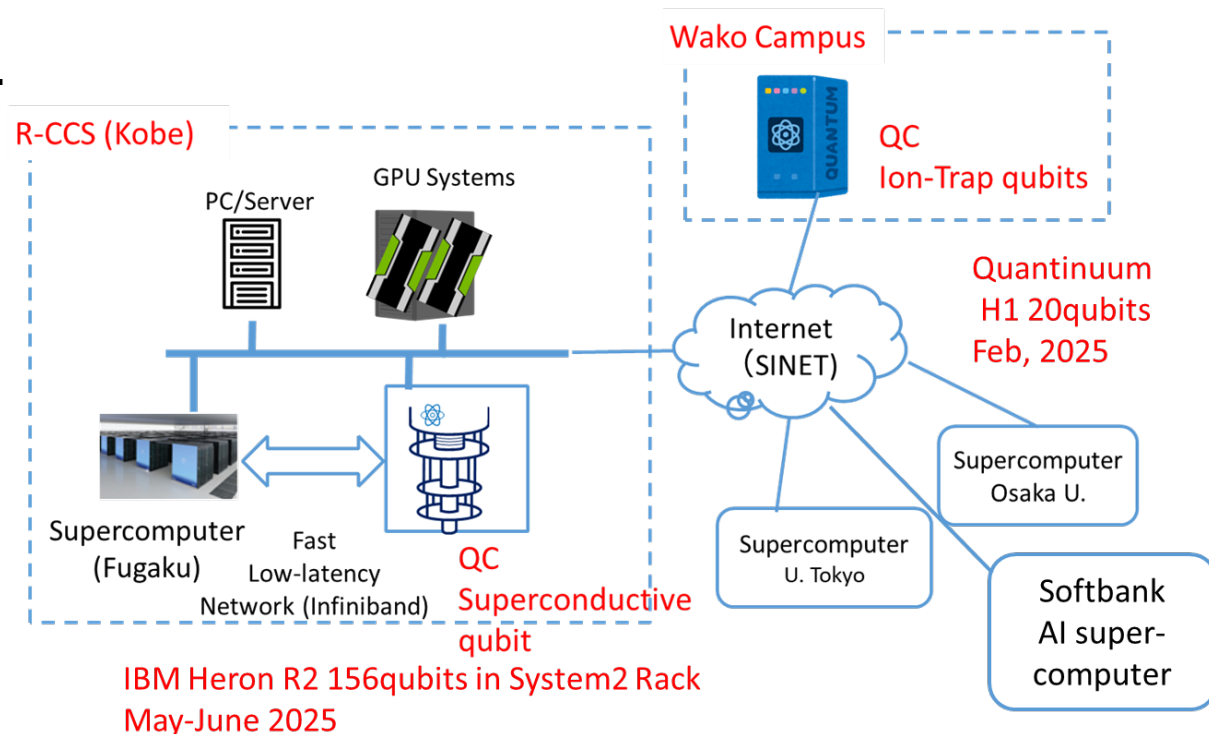

初々明  
QUANTINUUM REIMEI

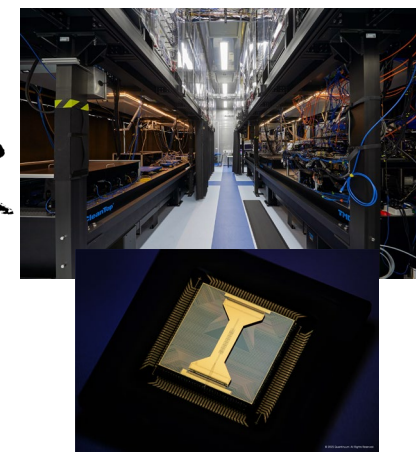

# QCSC (Quantum Centric Supercomputing)

## Why QC-HPC hybrid computing?

- Many problems can be solved using supercomputers (HPC), but problems requiring exponential execution time cannot be solved even with supercomputers.
  - Quantum simulation, optimization, graph problems, cryptanalysis, factorization ...

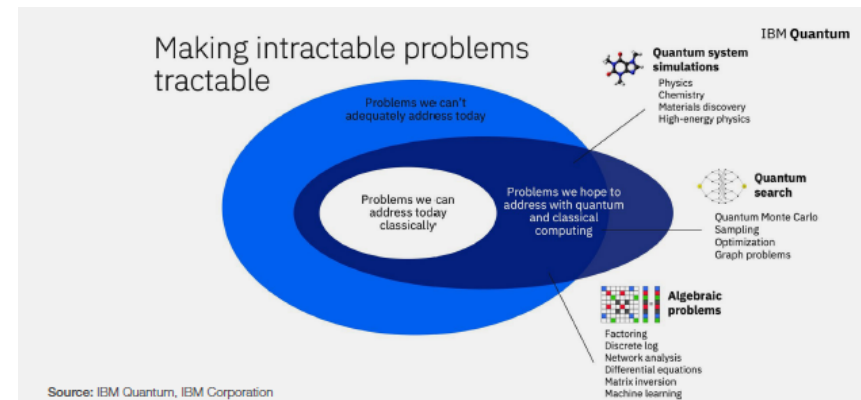

- **When solving large and realistic scientific problems using QC, combining with HPC is required for many computation including preprocessing, postprocessing, etc.**
  - In quantum many-body problems, the computation that generates the model is well-suited to supercomputers and sufficiently fast. Considering realistic speed and scalability, replacing everything with a quantum computer is not practical.
  - In the future, when inputting quantum states at scales of hundreds or thousands of qubits, HPC will be necessary to prepare these states.
- **Particularly in quantum chemistry and material science, combining QC with existing quantum chemistry applications (approximate solution methods) on HPC is essential.**
  - Effective use of QC involves first obtaining a “variational state approximately close to the true ground state” using HPC, then making use of the quantum computer.
  - Similarly, for energy calculations on large molecules, it is necessary to identify the portions truly requiring QC, and this requires HPC

# IBM\_kobe System Two in R-CCS@Kobe

**IBM kobe was installed in R-CCS in June!**  
**Heron R2 QPU (156 qubits) in IBM system two.**

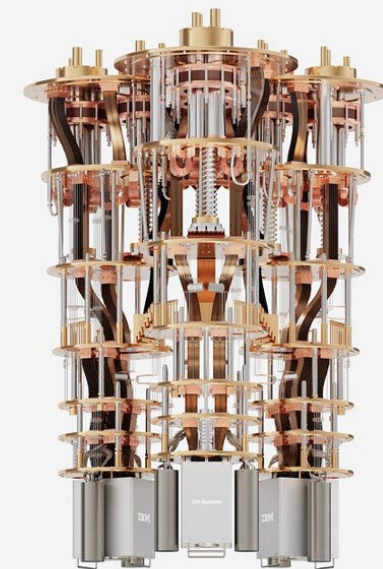
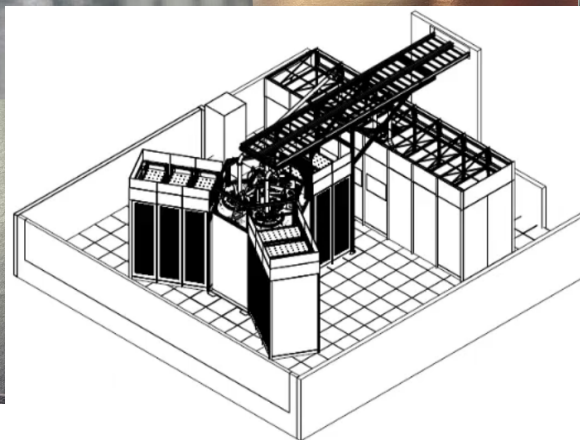
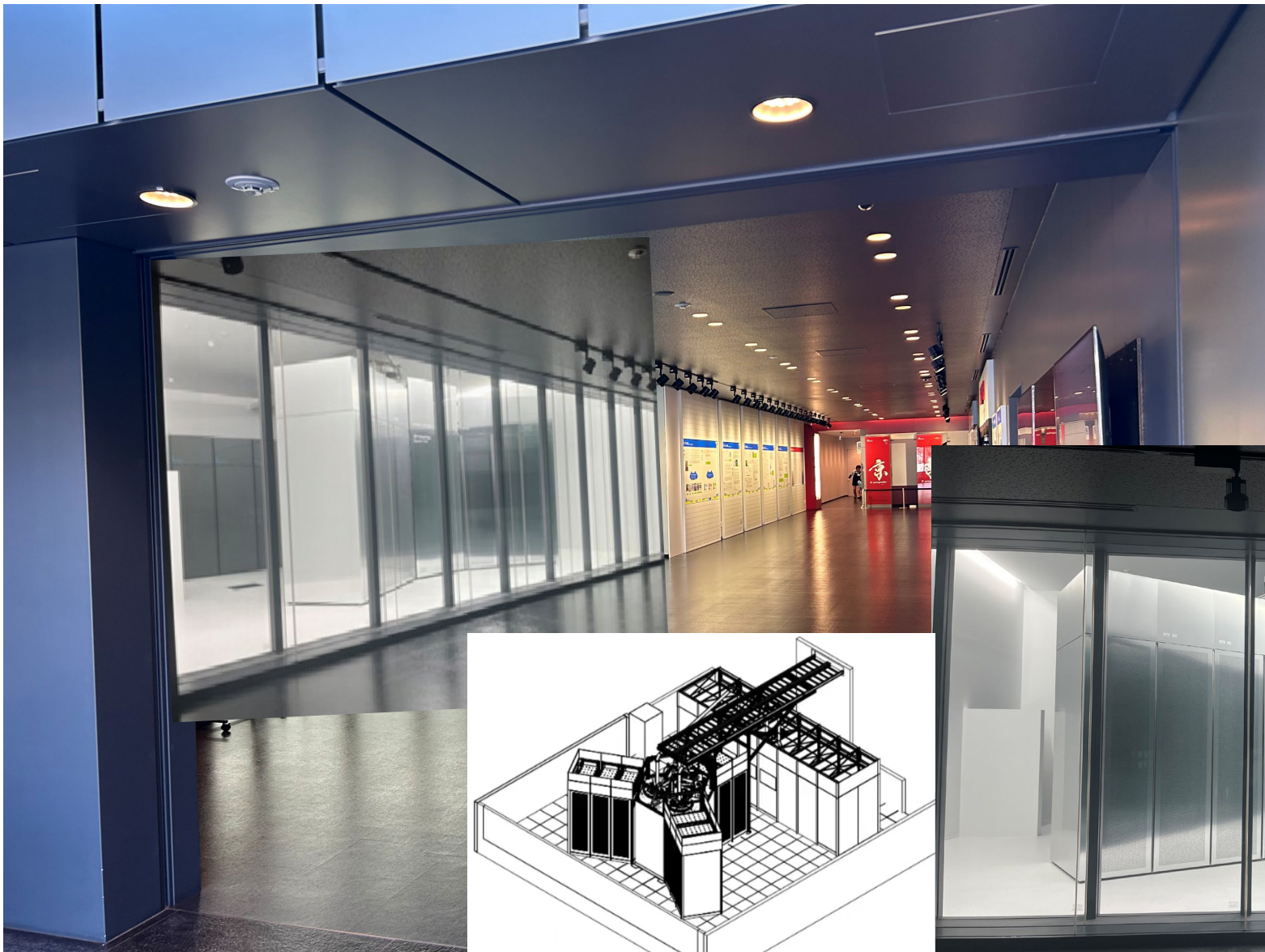

System 2 can contain 3 QPUs, but we have only Heron R2 1 QPU

# "Remei" Quantinuum Trapped-Ion Quantum Computer

初  
明

QUANTINUM  
REIMEI

Quantinuum Trapped-Ion Quantum Computer H1 (20 qubits) was installed in Wako Campus, Japan and is operated since Feb, 2025.

Remei, H1, is being upgraded to H2 (56 qubits) in April to Oct 2026!

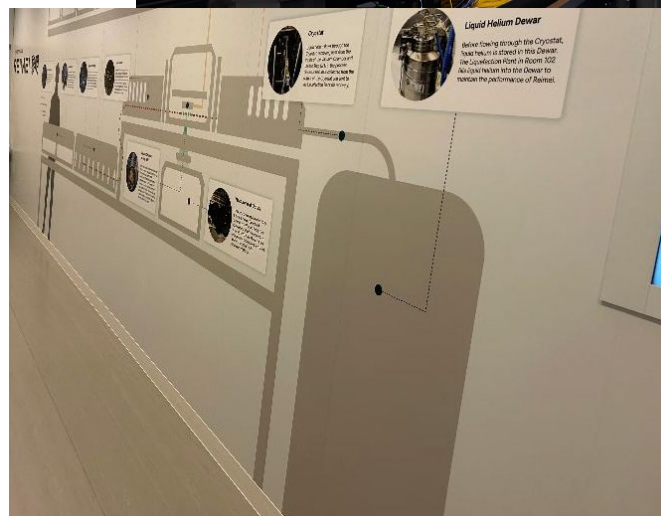
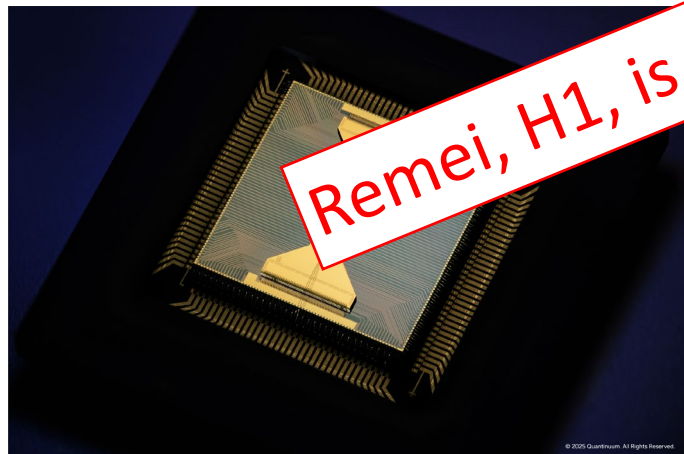

# Why IBM and Quantinuum?

QC qubits	Characteristics	Targets
Superconducting Qubits (IBM)	Medium qubit count (100 qubits or more) Fast operating speed (a few ns). Medium Fidelity.	Development of utilization technology and system software for the utilization and practical use of large- and medium-scale NISQ machines.
Trapped Ion Qubits (Quantinuum)	High fidelity, the number of qubits is not large.(about 20 qubits). Slow operation speed (a few ms). Efficient all-to-all qubit operation.	Software development using small scale but high fidelity. Use of quantum computers with properties different from superconducting qubits.

- **System software for QC-HPC integration should be able to support different kinds of QCs (QC-agnostic system).**
- **Quantum computers differ in their characteristics such as speed, fidelity, etc.**
  - Superconducting quantum computers are reaching the scale of several hundred qubits. In order to aim practical use of QC including NISQ, we should explore use-case using large qubits for practical use.
  - Quantinuum provides high-fidelity and deep circuit.

# Programming Models for QC-HPC Hybrid Apps

## How to combine QC and HPC

- (0) Running Qiskit program on a single node as in "Cloud"
- (1) Loosely-coupled independent programs of QC and HPC by workflow tools
- (2) Tightly-coupled QC and HPC in one HPC program by **offloading of QC computation using (asynchronous) RPC** (remote procedure call)  
 ⇒ **by priority-based scheduling**

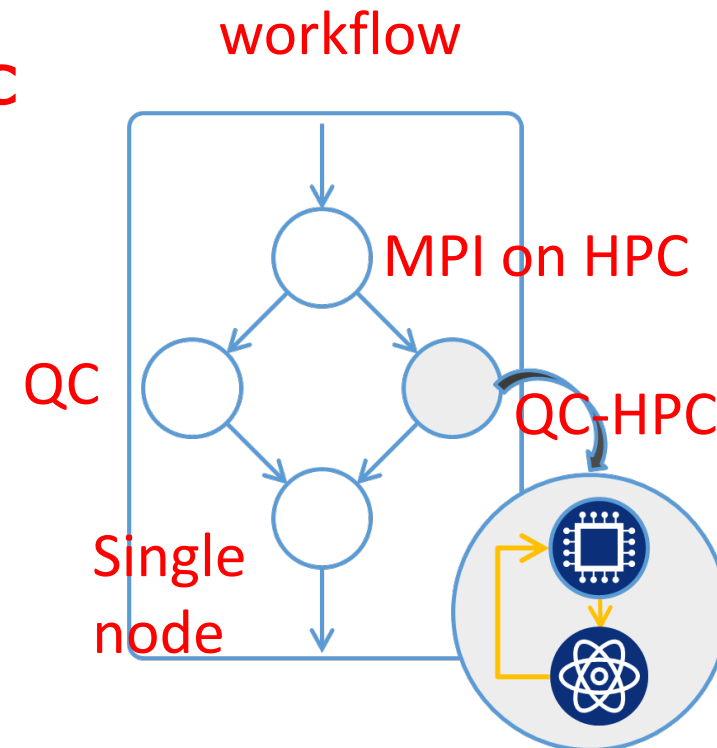
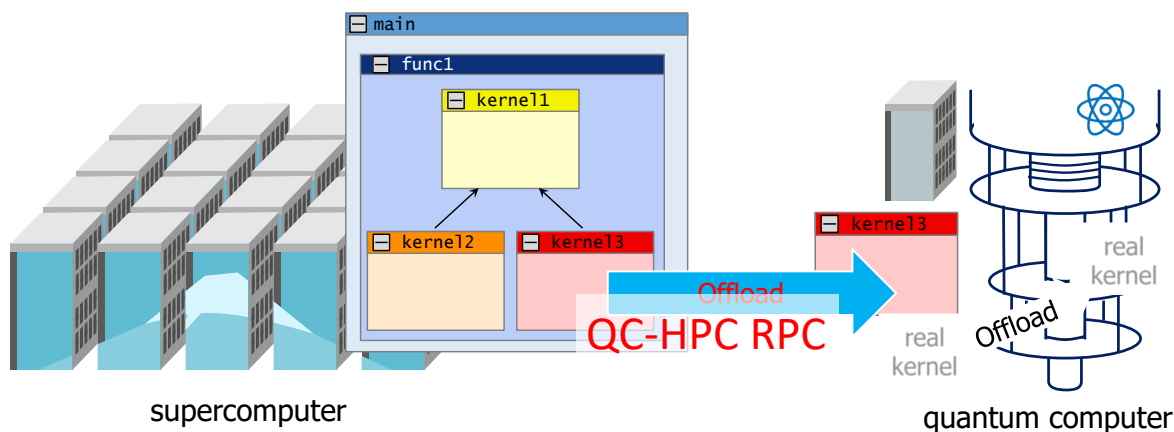
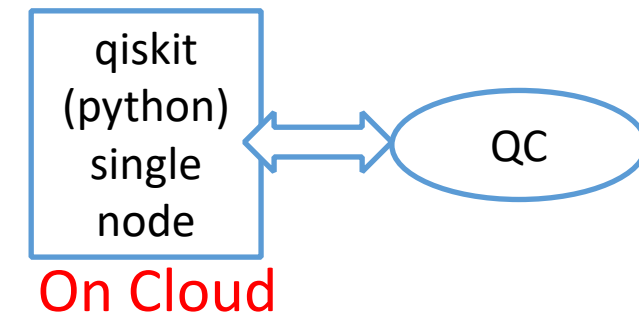

- **Two ways to access QC**
  - Our SQC APIs and RPC. The RPC uses direct access APIs provided by QPU vendors
  - REST-APIs through vender clouds
- **Workflow tools**
  - Tierkreis (Quantinuum), Prefect, Xcrypt
- **QC software libraries**
  - JHPC Quantum QC software lib
  - Qunasys QURI SDK
  - Error mitigation
  - Error suppression

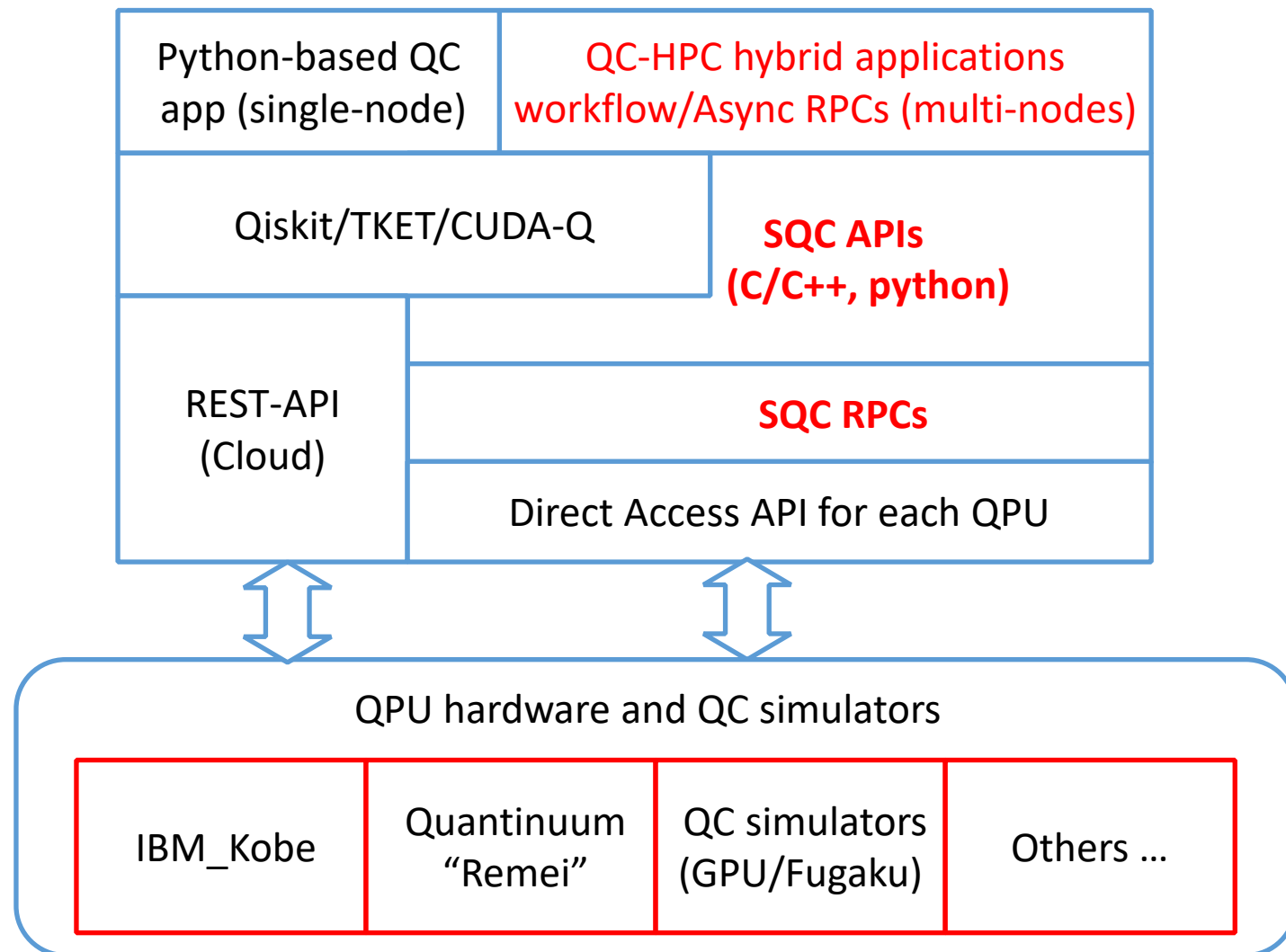

- **The following application areas are being focused on for “Utility-Scale” QC-HPC hybrid computing**
  - **Quantum Chemistry**
  - Quantum Machine Learning
  - CAE: QC-HPC for fluid dynamics
- **Two experiences for QC-HPC Quantum Chemistry applications**
  - **Ground state energy calculation of [4Fe-4S] clusters by Sample-based quantum diagonalization (SQD)**
    - **Effort for Quantum-centric Supercomputing (QCSC) with IBM and RIKEN**
    - SQD by Herion QPU and a large number of nodes of Fugaku (150K nodes)
    - Tightly-Coupled programming models and diagonalization by large-number of nodes.
  - **Biomolecular chemical reactions by QC-HPC hybrid computing workflow**
    - **Effort on Biochemistry with Quantinuum and RIKEN**
    - Loosely coupled programming models by Quantinuum TierKreis workflow tools
    - Photo-isomerization of retinal. Use NTChem developed by R-CCS executed in Fugaku for environment and QC for reaction centers

- **Sample-Based Quantum Diagonalization (SQD)**

- “a classical post-processing technique which acts on samples obtained from a quantum circuit after execution on a QPU. It is useful for finding eigenvalues and eigenvectors of quantum operators, such as the Hamiltonian of a quantum system, and uses quantum and distributed classical computing together.”

(from IBM web site)

<https://docs.quantum.ibm.com/guides/qiskit-addons-sqd>

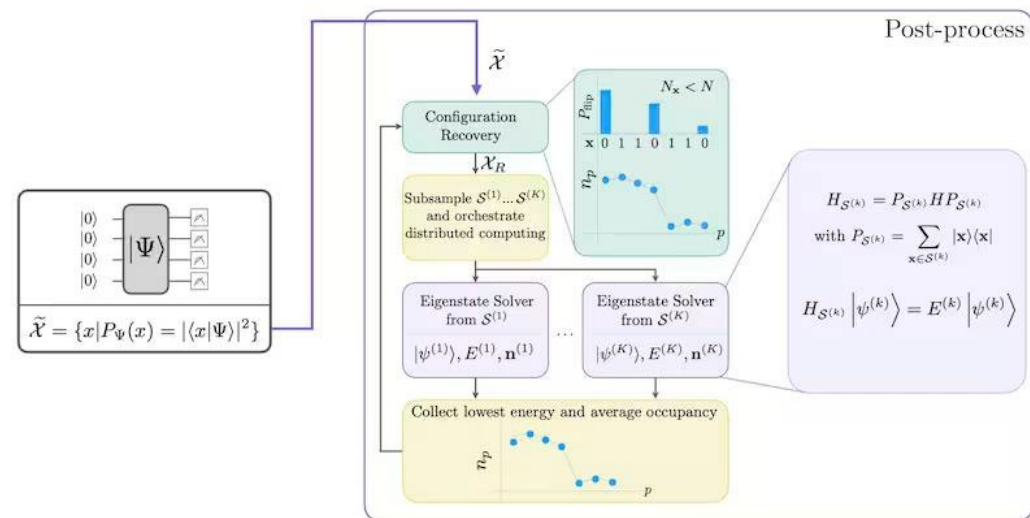

- We already demonstrated to incorporate quantum computations of chemistry in a quantum-centric supercomputing architecture, using up to **6400 nodes of the supercomputer Fugaku** to assist a **Heron superconducting quantum processor**. (2024)

- We simulate the N2 triple bond breaking in a correlation-consistent cc-pVDZ basis set, and the active-space electronic structure of [2Fe-2S] and [4Fe-4S] clusters, using 58, 45 and 77 qubits respectively, with quantum circuits of up to 10570 (3590 2-qubit) quantum gates.

**J. Robledo-Moreno et al., arXiv:2405.05068**

- In this study, calculations are performed on a supercomputer using quantum computer results



- Execution with large-scale HPC: Closed-loop Iterative calculations were performed with tight integration **by** exchanging data at run-time **with large-scale node of Fugaku (2026)**

# Closed-loop calculations of electronic structure on a quantum processor and a classical supercomputer at full scale (2025)

## New algorithms

Optimize parameters of LUCJ circuits with iterations

## New diagonalization

Fast diagonalization tool. 100x speedup

## Tightly coupled workflow for closed-loop for overlapping QC and HPC

Implementing the algorithms with feedback loop, tight coupling, orchestration of resources

150 mEh improvement over 2024 demo

Efficiently utilize capabilities of Heron r2 (ibm\_kobe) and 16K Fugaku computation nodes

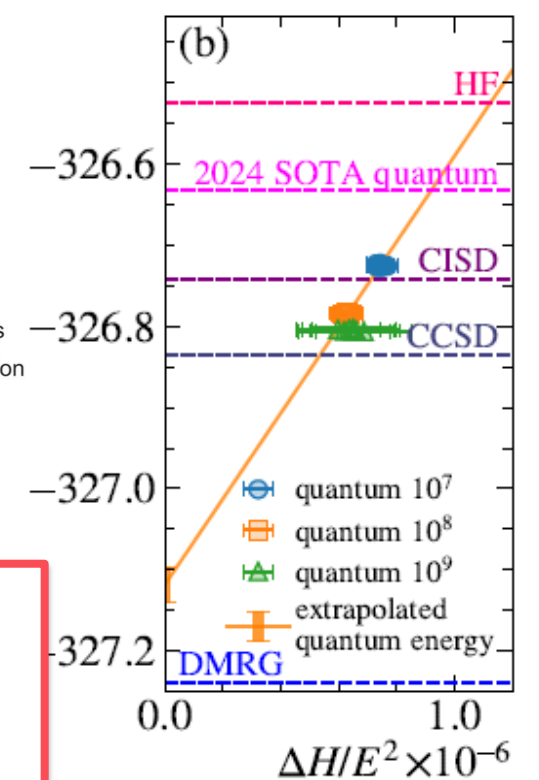
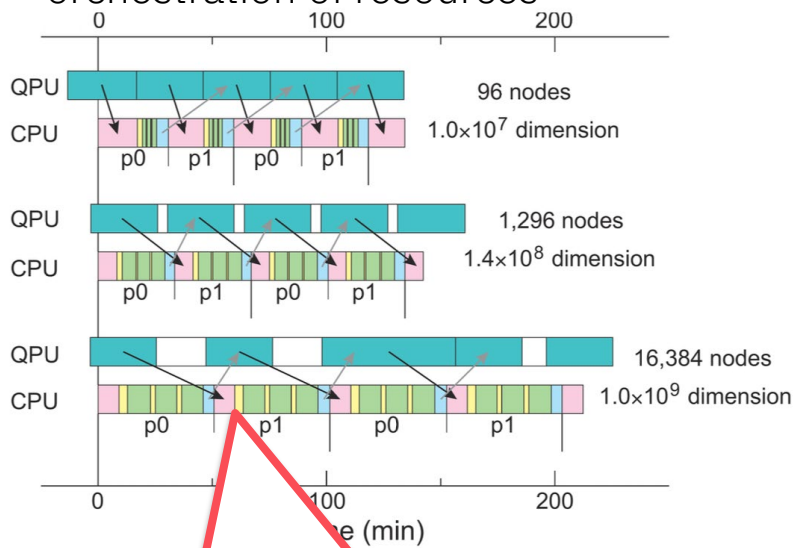
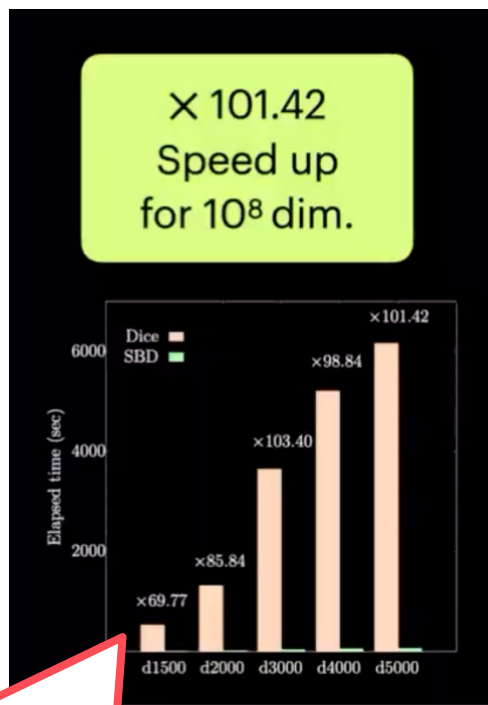
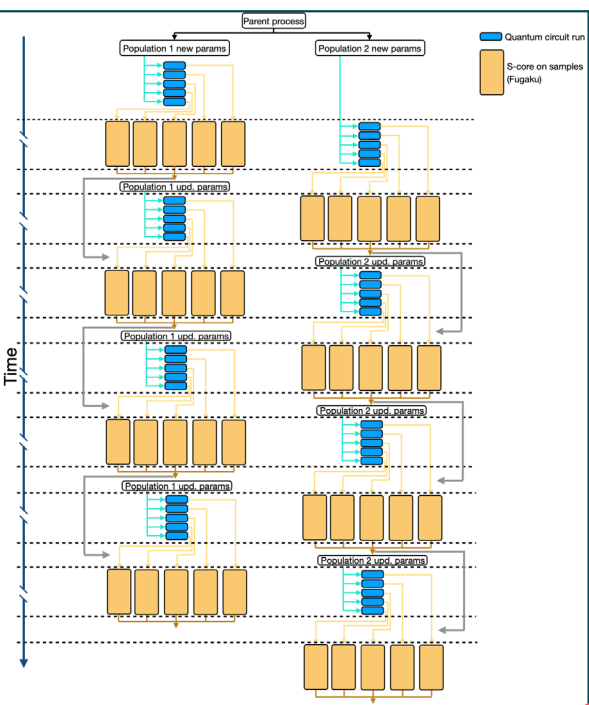

Implemented by MPI for using a large-scale of nodes in Fugaku

1.0 x 10<sup>9</sup> dimensions  
Overlap between CPU and QPU computations by tight-coupled Use 16K nodes of Fugaku integrations with Fugaku and Heron

# Demonstration by loosely-coupled QC-HPC applications in Quantinuum TierKreis workflow

## Demo: Biomolecular chemical reactions

Retinal embedded in bacteriorhodopsin, for example.

- Selective photo-isomerization occurs **only** in a **specific environment**.
- Environment (protein backbone)
  - Large in size, weak in electronic correlation

→ **HPC**
- Reaction center (embedded retinal)
  - Small in size, strong in electronic correlation

→ **Quantum Computers**

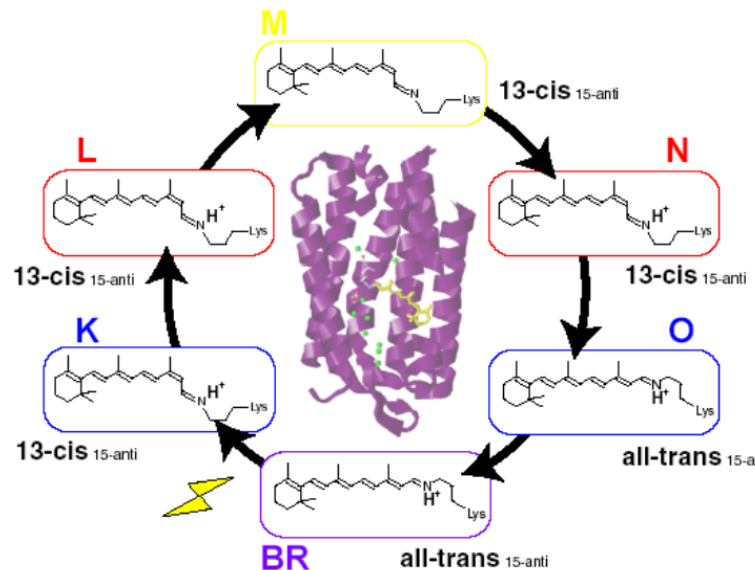

Sensors 2009, 9(12), 9741-9804; <https://doi.org/10.3390/s91209741>

**QC-HPC hybrid system naturally fits the feature of the target → Promising application**

Use NTChem developed by R-CCS executed in Fugaku for environment and QC for reaction centers

Workflow by Quantinuum TierKreis workflow tools

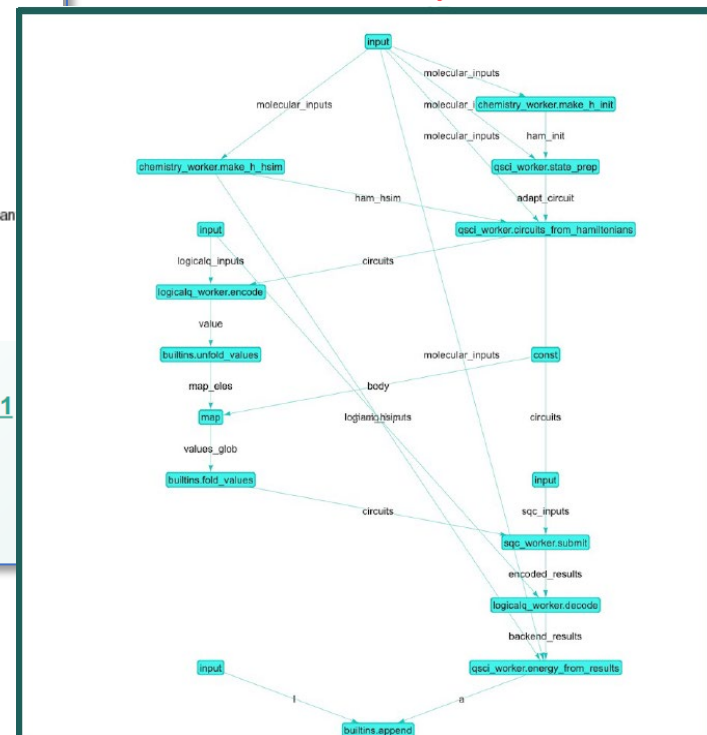

## QC-HPC for fluid dynamics by R-CCS Tsubokura Team

### SC25 Best Poster Award Winning Paper

### "Time-Stepping Hamiltonian Simulation via Quantum-Classical Hybrid Approach for Solving Nonlinear Partial Differential Equations"

- \* **Expanded application range of quantum computation: By using a special mathematical transformation called "Schrödingerization,"** it enables computation of physical phenomena where energy dissipates (e.g., heat conduction, viscous fluids), which quantum computers are inherently poor at.
- \* **Established a practical hybrid method for fluid dynamics:** Conventional methods require an exponential increase in qubit count, making computation difficult on current NISQ (Noisy Intermediate-Scale Quantum) devices. **This research processes the difficult "nonlinear parts" sequentially on classical computers, combining them with quantum computation to achieve high-precision results with fewer quantum resources.**
- \* **Demonstrated effectiveness in real-world problems:** Simulations were performed on standard models in fluid dynamics (Burgers' equation) and materials science (Allen-Cahn equation), demonstrating accuracy comparable to classical computation.

【Policy Implications】 This achievement shows a path to solving complex nonlinear problems in the real world through "collaboration between current noisy quantum computers (NISQ) and supercomputers (hybrid)," without waiting for full-scale quantum computers.

=> **Key technological foundation for future HPC-QC collaboration strategies**

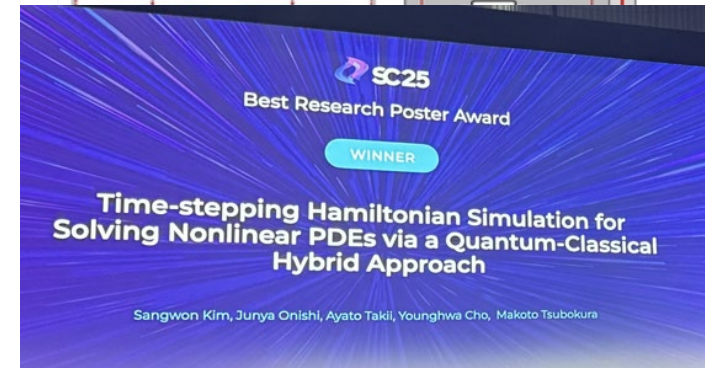
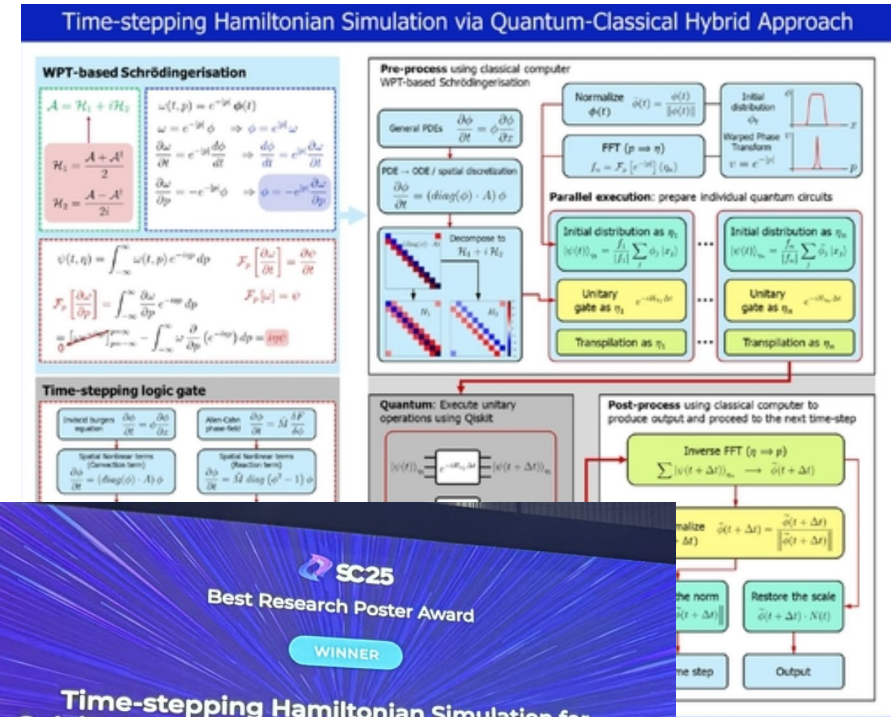

# JHPC Quantum QC-HPC hybrid computing Platform

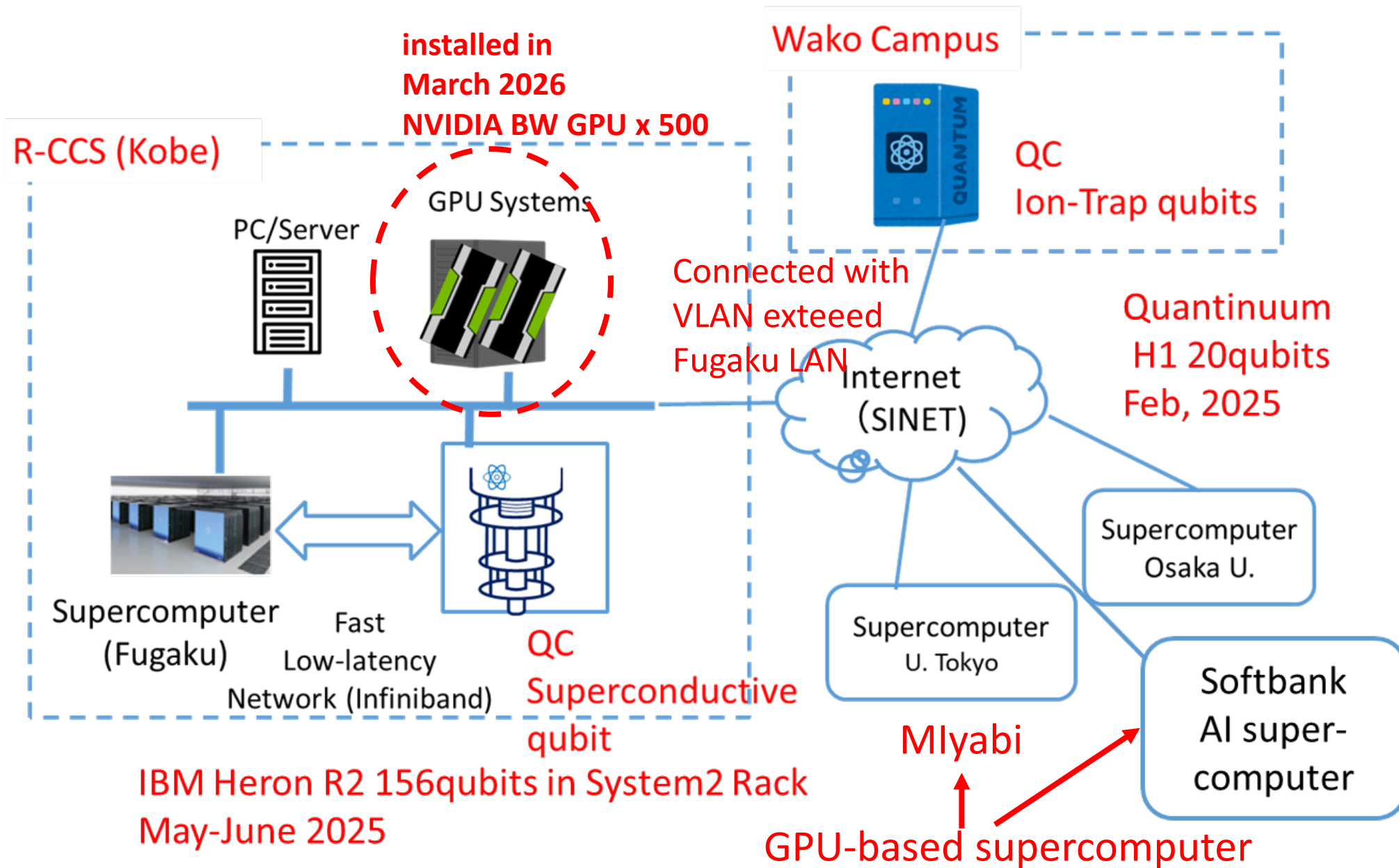

# Roquo: QC-HPC GPU Supercomputer Overview

## ■ Background/Objectives

1. Quantum computer simulator, especially using tensor-based methods
2. Execute Classical part of the QC-HPC computing

## ■ System Configuration

- Giga Computing Technology servers, integration ScaleworX
- 135 nodes with NVIDIA Grace Blackwell superchips (540 GPUs).
- Inter-node connection: NVIDIA InfiniBand XDR (up to 3.2Tbps).
- Performance: Over 21 PFLOPS (FP64), over 5 EFLOPS (FP8).
- Supports warm-water cooling, balancing high performance and energy efficiency.



## ■ Future Plans

- Construction completion within FY2025 (March 2026), full operation start from early FY2026. (April/May 2026)
- Co-operation with "AI for Science" GPU supercomputer => total #GPU => 2140 GPUs (NVIDIA GB200)

Under construction  
As of March 8, 2026

# How to combine QC and GPU

- **Execute HPC for classical parts in HPC-QC**
- **Quantum Machine Learning : executing ML on quantum**
  - Transfer Learning with ML/GPU and QML
- **Using ML on GPU to generate a smart QC circuit**
  - QC circuit optimization using GPU and ML
- **AI-assisted QC algorithm**
  - QC Error mitigation by advanced technique such as ML on GPU
  - NVIDIA GQE (GPU-accelerated Quantum Eigensolver) , ADAPR-GQE, ...
- **QC simulation on GPU clusters**
  - Optimization for state-vector simulator (RIKEN-bracket)
  - GPU support for tensor operation in tensor network-based simulators
- **Tightly connected architecture for quantum error correction (QEC)**
  - Direct I/O with NVQLINK
  - Realtime high-performance processing by a set of GPUs (HPC?)

# TRIP3 project for EC and FTQC

- TRIP3 project is aiming to conduct research QC-HPC for RIKEN QC 叢 (“A”) and its successors
- POC experiment to connect Fugaku and “A” in 2023
- 64qubit x 2 system will be available.
- We are starting researches towards FTQC
  - Using NVQLink with NVIDIA GPU and FPGA

NVIDIA  
GPU +  
NVQLINK

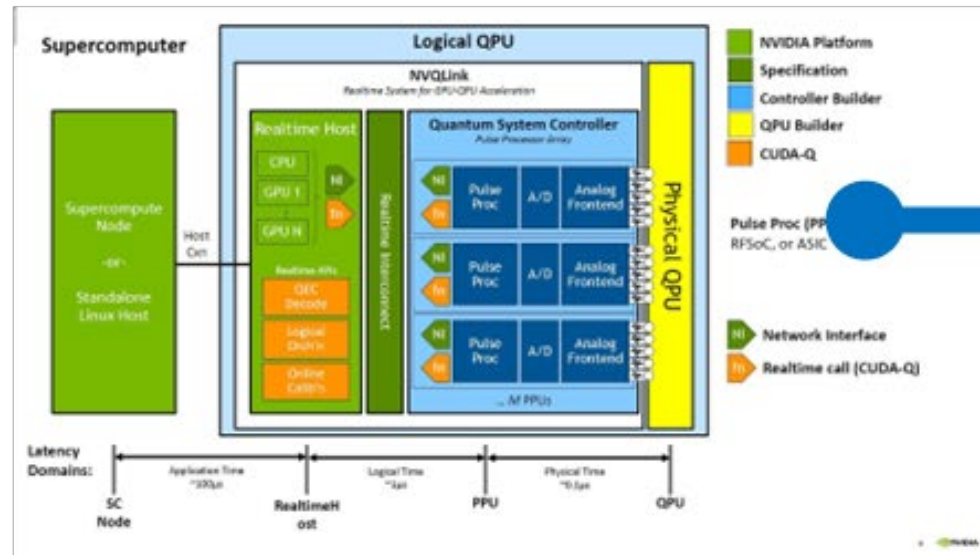

## EU

- CEA (France) \*
- BasQ (Basque country) \*
- LRZ/TUM (Germany)
- JSC (Germany)
- BSC (Spain)
- CSC (Finland)

## US

- ORNL \*
- ANL
- LBNL
- PRI (Rensselaer Polytechnic Institute) \*
- Cleveland Clinic \* ★

- \* MoU is done
- IBM site
- ★ TUP Partner

## Aisa-Pacific

- Yonsei University \* \*
- IHPC/A-Star @ Singapore \*
- AIST/G-Quad

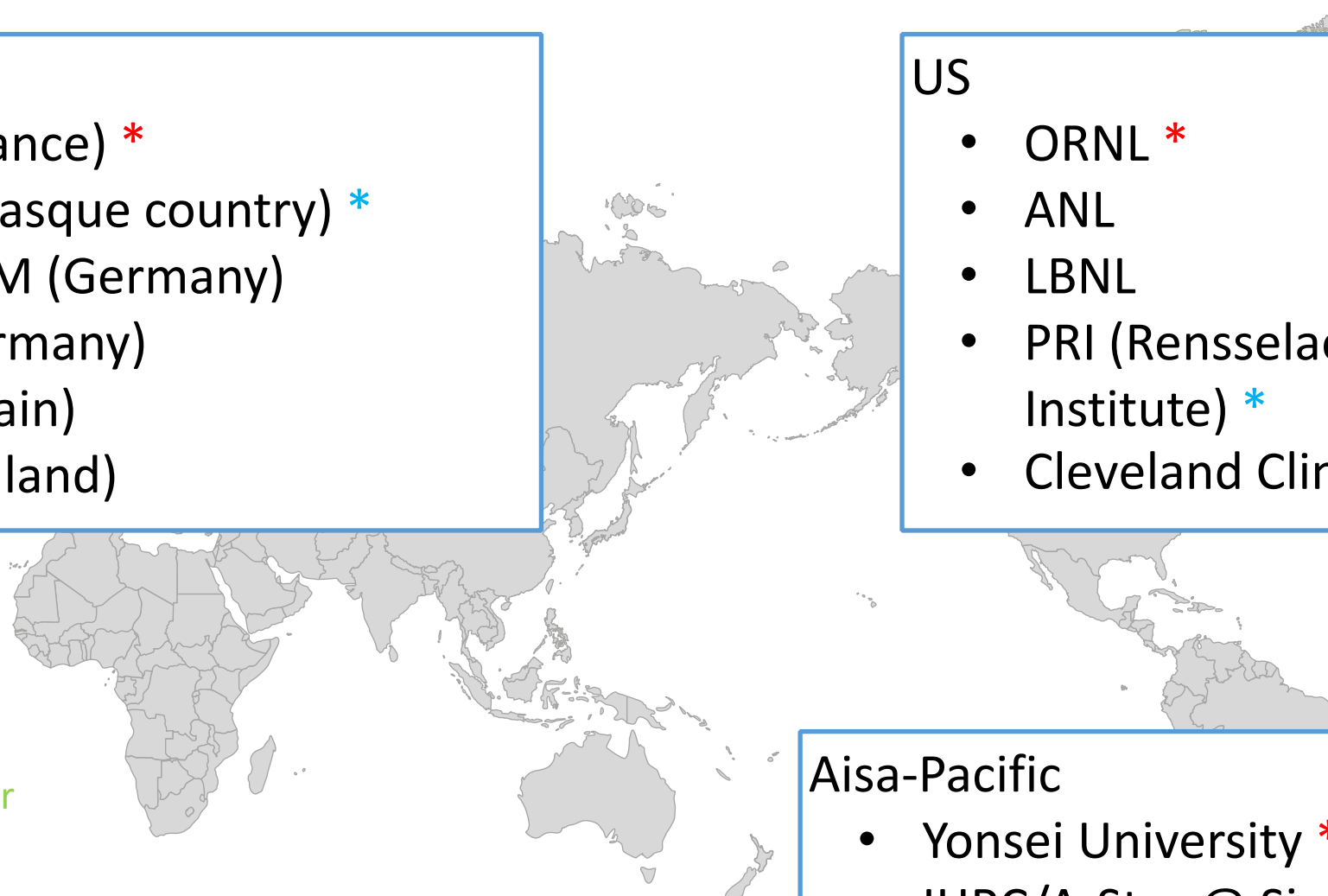

- **Objectives**

- Evaluation and Feedback from Test Users for improvement of our system software and platform of QC-HPC hybrid computing
- Contribution to QC-HPC hybrid computing technology and “Quantum Utility”
- Fostering a user community of QC-HPC hybrid computing

- **Web site:**

[https://jhpc-quantum.org/jhpc-quantum\\_tup-april/](https://jhpc-quantum.org/jhpc-quantum_tup-april/)



## *JHPC-Quantum Quantum-HPC Hybrid Platform*

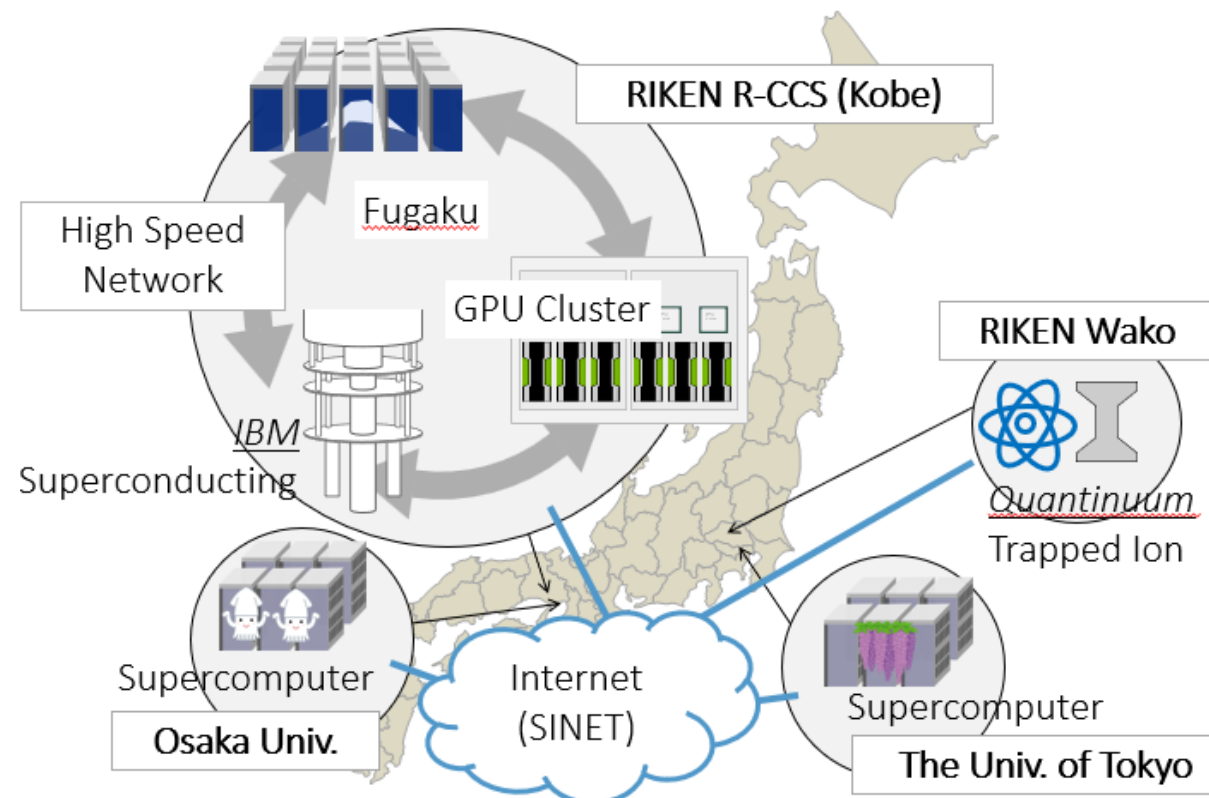

- TUP Call for application proposals to utilize the hybrid platform to research and develop quantum-HPC hybrid applications
- 21 proposals were accepted in TUP 2025
- International TUP projects
  - Cleveland Clinic@US
  - Qunova@Korea

User	Application area
JSR Corporation	Materials
Toyota Motor Corporation	Materials, Design & Manufacturing
SoftBank Corp.	Materials
Ochanomizu University	Natural Sciences
Toyota Central R&D Labs., Inc.	Design & Manufacturing
Kyoto University	Medical, Drug Discovery
Oita University	Medical, Drug Discovery
The University of Electro-Communications	Natural Sciences
Mitsubishi Chemical Corporation	Materials
and more ..	

**New call for TUP  
2026 will open in  
May 2026 !!!**